

customer/technical services

For any technical or installation queries please contact Vado on 01934 745163.

guarantee

This product is guaranteed against manufacturing defects from the date of purchase until the expiry of the relevant guarantee period shown below.

The guarantee is only valid if:-

1. The product has been installed, used and maintained in accordance with Vado's instructions and subjected to normal use only.
2. The defect is not due to use of an unsuitable or inadequate water or power supply.
3. The defect is not due to accident, misuse, neglect or repair other than by Vado or Vado authorised agents or damage caused by foreign objects or substances.
4. We have received from you the completed Guarantee Registration Form. Vado accepts no responsibility for any forms lost in the post and returns by registered means is therefore recommended.

Under this guarantee (which is non-transferable) Vado will, at its option, repair or replace free of charge any product (or replacement part) found to be defective. The guarantee does not extend to any consequential loss or damage. After repair or replacement the relevant guarantee period will be calculated from the original date of purchase.

The relevant guarantee periods are:-

1. Twelve years on chrome finish products.
2. Three years on all other products with the exception of Stuart Turner Pumps which carry a 2 year Guarantee on Monsoon Range and 1 Year Guarantee on Showermate Range.

All claims under the guarantee must be submitted in writing to the person who supplied the product to you and must be received no later than the last day of the relevant guarantee period. All claims must be accompanied by proof of purchase (sales receipt or delivery note).

Vado operates a policy of continuous product development and therefore reserves the right to change the product, packaging and documentation specifications without notice.

This guarantee is in addition to and does not affect your statutory rights as a consumer.

Vado

Wedmore Road, Cheddar, Somerset, England BS27 3EB
tel 01934 744466. fax 01934 744345
technical@vado-uk.com
www.vado-uk.com

GUARANTEE REGISTRATION

NAME				
ADDRESS				
	POSTCODE			
RETAILER				
ADDRESS				
	POSTCODE			
PURCHASE DATE	ARTICLE NUMBER	(SEE BOX)		
PRODUCT DESCRIPTION				
WHO INSTALLED THE PRODUCT?	RETAILER	PLUMBER	BUILDER	SELF
FOR VADO USE				



installation & maintenance instructions

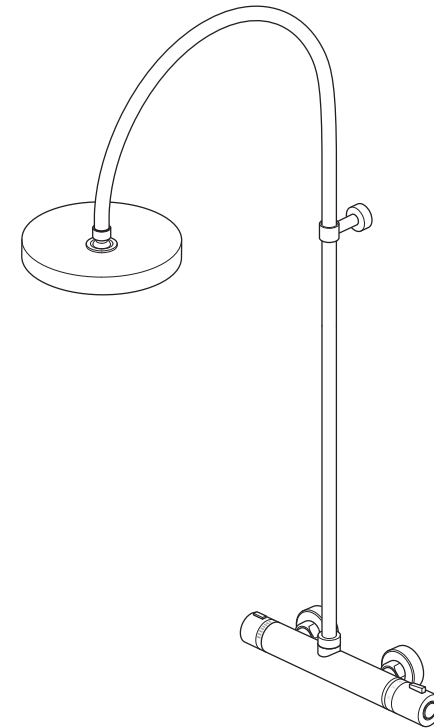

velo

exposed thermostatic shower mixer

please leave these instructions with the customer

important - please read

Please read these instructions carefully before starting installation and keep for future reference.

Remove all packaging and check the product for missing parts or damage before starting installation.

Any alterations made to this product and fittings may infringe water regulations and will invalidate the guarantee.

The installation must comply with all Local/National Water Supply Authority Regulations/Byelaws and Building and Plumbing (UK:BS6700) Regulations.

We strongly recommend that you use a qualified and registered plumber.

Installer must comply with current regulations.

Please note if installing in an enclosed environment, access should be left for servicing and maintenance. No costs relating to inadequate access can be accepted.

care of the mixer

Our products are finished to the highest standard and due care needs to be taken to ensure their looks are retained.

We recommend cleaning all products with a soft damp cloth ONLY and advise strongly against the use of ALL cleaning products i.e. powders and liquids.

If the above instructions are not followed this will invalidate your guarantee in the event of a problem occurring.

maintenance

To remove any build up of limestone on the showerhead, just rub your fingers lightly over the nozzles.

operation

Moving the handle controls the flow of water.

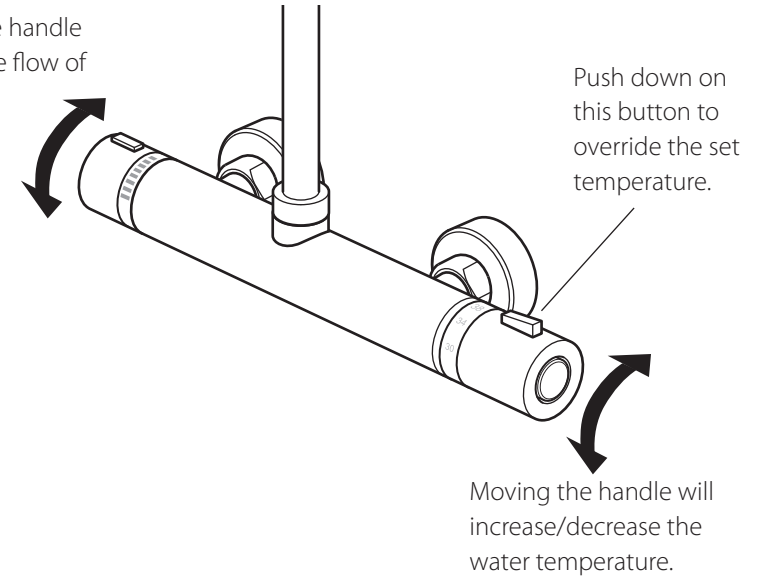

temperature resetting

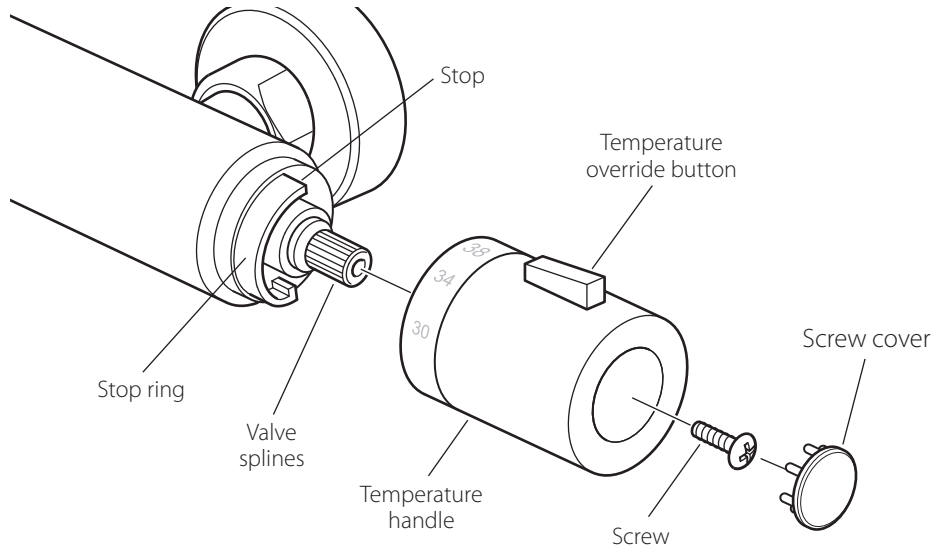

The valve has been factory set under balance pressures and hot water supply at 65° C. When your specific operating conditions are significantly different from the above, the temperature of the water may vary from the setting.

When the difference is too great, you can adjust the calibration of the valve to suit individual requirements of the installation:

1. Select 38° C on the handle and check the temperature of the water being delivered to the outlet with a thermometer.
2. If the temperature is unacceptable proceed to reset the calibration as follows: Remove the handle (do not remove the stop ring). Turn the spline of the valve clockwise to decrease the temperature and anti-clockwise to increase the temperature until 38° is achieved.
3. Ensure that the stop on the stop ring is pointing at 12 o'clock, replace handle with the temperature override button pointing at 12 o'clock being careful not to turn the splines of the valve.

The valve setting is now calibrated to suit your requirements.

dimensions

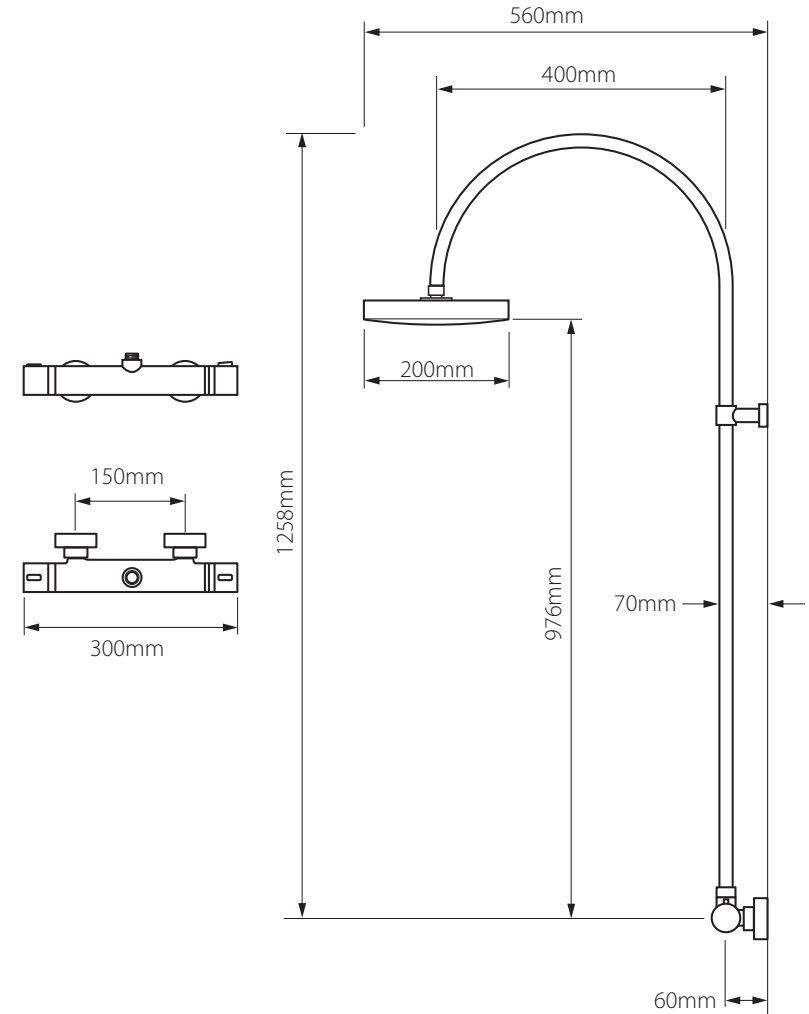

Operating Specifications

Hot Water Supply Temperature:

Maximum: 85° C

Minimum: 10° C higher than the maximum required mixed temperature (advise 65° C)

Operating Pressure:

Minimum operating pressure 1.5 bar

Maximum operating pressure 5 bar

installation

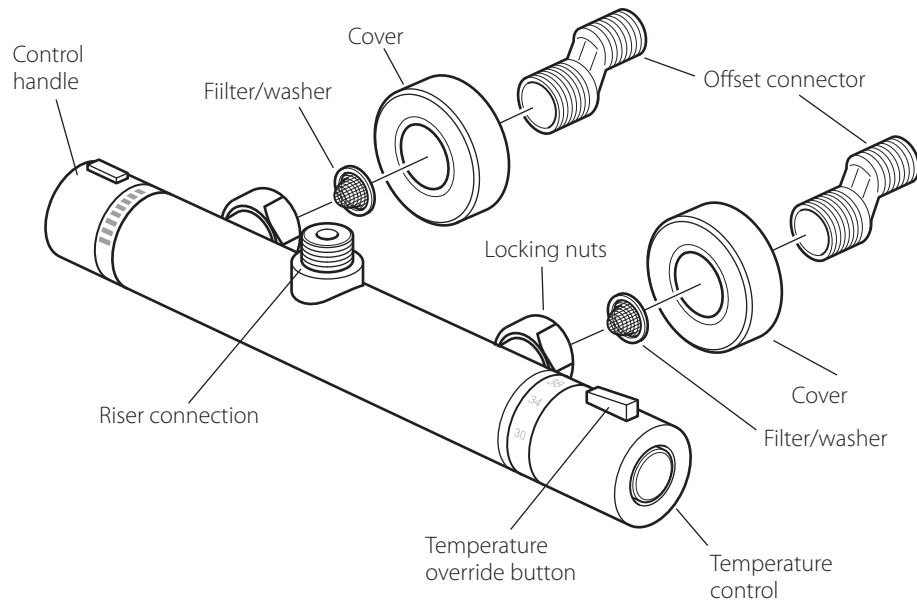

Before installing your new mixer, flush through the pipework to ensure removal of debris, turn off the water supply.

Prepare the wall with 2 flush $\frac{1}{2}$ " connectors at 150mm centres. Connect the water supply to the inlet pipes. The hot water should be connected to the left hand pipe. Screw on the 2 offset connectors followed by the covers.

Place a filter/washer in each of the locking nuts on the valve and screw onto the connectors, some adjustment can be made to the offset connectors to align the centres and level up the valve.

Note: If you are installing this item using our fixing brackets (product code: WG-049BRACK+SHR-C/P) please ensure a $\frac{3}{4}$ fibre washer is used in addition to the mesh filter washers in the valve inlets in order to create a watertight seal.

Also due to the location of the NRVs (Non Return Valves) in the offset connector, when using the WG-049 Bracket and Shroud an additional NRV must be fitted in line to each of the hot and cold supplies.

installation

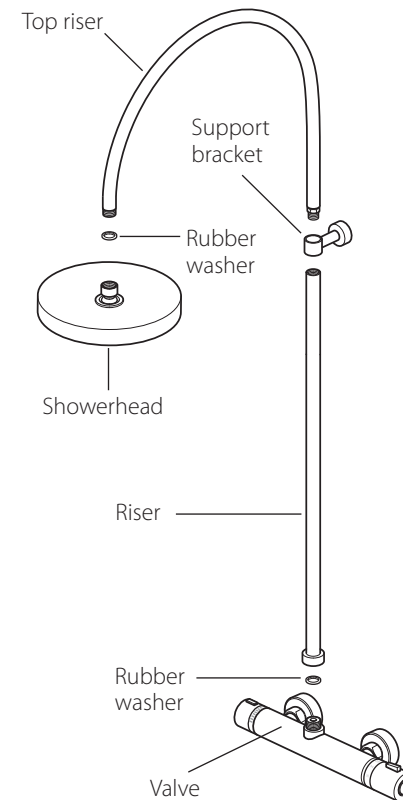
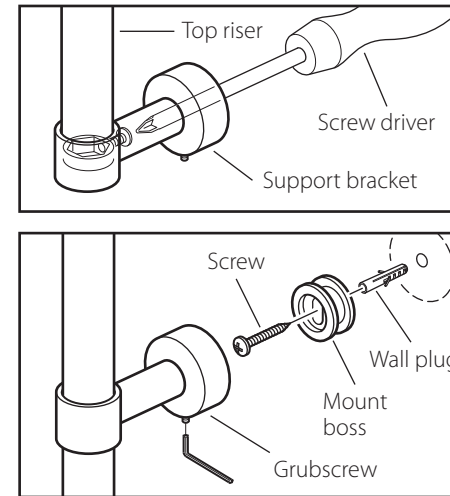

Warning! Please check for any hidden cables and pipes before drilling holes in the wall.

Assemble by pushing the top riser into the bracket locating the flats of the nut, make sure that the hoop of the top riser is pointing away from the wall and the grubscrew is on the underside of the bracket. Tighten the screw within the bracket to secure together using a cross head screwdriver.

Screw the riser into the bottom of the bracket.

Mark a line up the wall from the centre of the valve. Screw the riser assembly loosely onto the valve and hold in position, with a pencil mark around the support bracket. Remove the riser assemble.

Using a 6mm drill bit for the wall plug, drill the wall at the centre of the marked position and fix the mount boss in position using the supplied wall plug and screw.

With a rubber washer refit the riser assembly into the valve, push the bracket onto the boss and secure from underneath with the hexagonal grubscrew, then tighten the nut onto the valve.

Finally, make sure there is a rubber washer in place in the showerhead and screw onto the top riser.